



STAINLESS STEEL SUBMERSIBLE PUMPS



All the internal and external metal components of the pump are constructed of stainless steel throughout and are being cold pressed from stainless sheet steel.

The bearings and the neck rings are made of special high nitrile content rubber to ensure excellent resistance to wear and abrasion by sand suspended in the well water.

Tous les composants métalliques internes et externes de la pompe sont fabriqués entièrement en acier inoxydable et proviennent de plaques d'inox pressées à froid.

Tous les joints sont fait d'un NBR spécial contenant du caoutchouc pour assurer l'excellente résistance à l'usure et l'abrasion provoquées par l'éventuel sable en suspension dans l'eau du puits.

Construction of the pump

Impeller

- 1 6 contact points on the shaft.
- 2 6 welding points on each vane.
- 3 5 different shapes and flows.
- 4 AISI 304 stainless steel sheet with thickness of minimum 1 mm.

Diffusor

- 5 Minimum sheet thickness 1mm.
- 6 Overdimensioned intermediate bearing at each pump stage.
- 7 Neck ring in NBR with reinforced stainless steel ring.

Top Bearing

- 8 Water-lubricated upper bearing in each pump.

Shaft

- 9 Hexagonal shaft in stainless steel AISI 304.
- 10 Pin to ensure motor torques up to 7,5 kW.



Construction de la pompe

La roue

- 6 points de contact avec l'axe 1
- 6 points de soudage par aube 2
- 5 différents débits et formes 3
- Tôle acier inoxydable AISI 304, épaisseur de 1 mm minimum 4

Le diffuseur

- Épaisseur minim. de tôle 1 mm 5
- Palier intermédiaire surdimensionné à chaque étage 6
- Joint Neck Ring renforcé d'une bague en acier inoxydable 7

Le palier supérieur

- Palier supérieur lubrifié à l'eau dans chaque pompe 8

L'axe

- Axe hexagonal en acier inoxydable AISI 304 9
- Goupille pour garantir le fonctionnement de moteurs jusqu'à 7,5 kW 10

Hydraulic Performances 50 Hz

Performances hydrauliques 50Hz

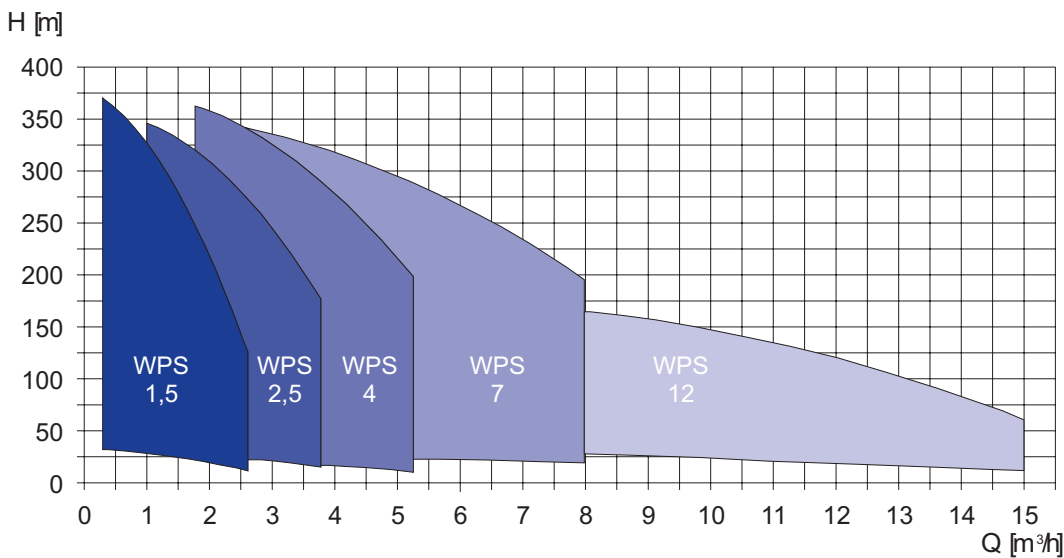

WPS 12

Pump identification code

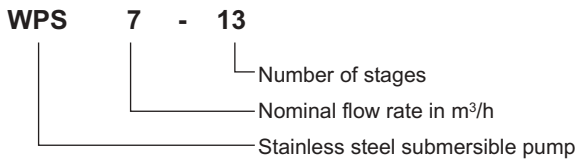

General specifications

Capacity from 0,5 to 15 m³/h
Head up to 410 meter.
Motor rating up to 7,5 kW (4" motor).
Vertical and horizontal position of operation.
Maximum fluid temperature 30°C (for higher temperatures, please contact us).
Maximum allowable amount of sand: 50 g/m³

Coupling with 4" Nema standard for motor assembly.
All parts out of stainless steel AISI 304 (W.-Nr. 1.4301).

Applications

Private and public water supply systems.
Sprinkler and drip irrigation systems.
Booster systems.
Fire fighting systems.
Fountains and water displays.
Other industrial applications.

Construction features

Coupling and flange suitable for motors with pump mounting dimensions in accordance with NEMA standards.
Jam free check valve, built into the discharge chamber, designed for low loss of head.
Oversized intermediate bearings located at each pump stage to align the shaft, specially designed to optimize lubrication.

Easy-to-replace wear-rings and bearings.
Rugged cable guard.
Hydraulic profiles are optimized for the attainment of high efficiencies.
Resistance to corrosion and abrasion, i.e. the same inherent qualities of stainless steel.
Very strong construction: minimum thickness of stainless steel sheet of 1 mm, 6 spot weldings on each vane, special top bearing for every pump, very rugged coupling on the shaft, 4 straps ...
Great ease of dismantling and assembly.

Code d'identification de la pompe

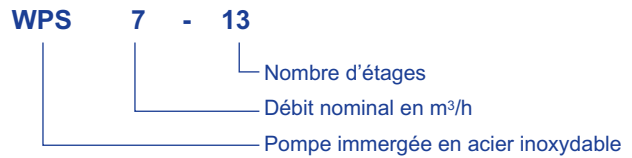

Spécifications générales

Capacité de 0,5 à 15 m³/h
Hauteur manométrique jusque 410 mètres.
Puissance moteur jusqu'à 7,5 kW (moteur 4").
Position de la pompe horizontale et verticale.
Température maximum de l'eau 30°C (pour des températures plus élevées, contactez nous).
Quantité maximale admissible de sable en suspension dans l'eau: 50 g/m³

Accouplement selon standard 4" Nema.
Les éléments fabriqués hors de l'acier inoxydable AISI 304.

Applications

Systèmes d'adduction d'eau privé et public.
Installations d'arrosage et d'irrigation en goutte à goutte.
Surpresseurs.
Systèmes anti-incendie.
Fontaines et plans d'eau.
Autres applications industrielles.

Caractéristiques de construction

Les dimensions des brides de pied et d'accouplement de la pompe correspondent aux normes standards NEMA.
Clapet anti-retour monté dans la tête de la pompe spécialement conçu pour un minimum de perte de charge.
Paliers surdimensionnés à chaque étage de la pompe pour un alignement parfait de l'axe. Ceux-ci ont été dessinés pour optimiser la lubrification.
Remplacement facile des rondelles d'usure et des paliers.
Protège câble très résistant.
Profils hydrauliques optimisés pour atteindre des rendements très élevés.
Résistance à la corrosion et à l'abrasion grâce à la qualité des composants de la pompe.
Construction très solide: tous les composants de la pompe ont une épaisseur minimale d'un millimètre, 6 points de soudage sur chaque aube, palier supérieur spécial pour chaque pompe, accouplement très résistant sur l'axe, 4 tirants, ...
Grande facilité d'assemblage et de démontage.



WELL PUMPS

**WPS Submersible Pumps
Type WPS 1,5**

Stainless Steel Submersible pumps 4"

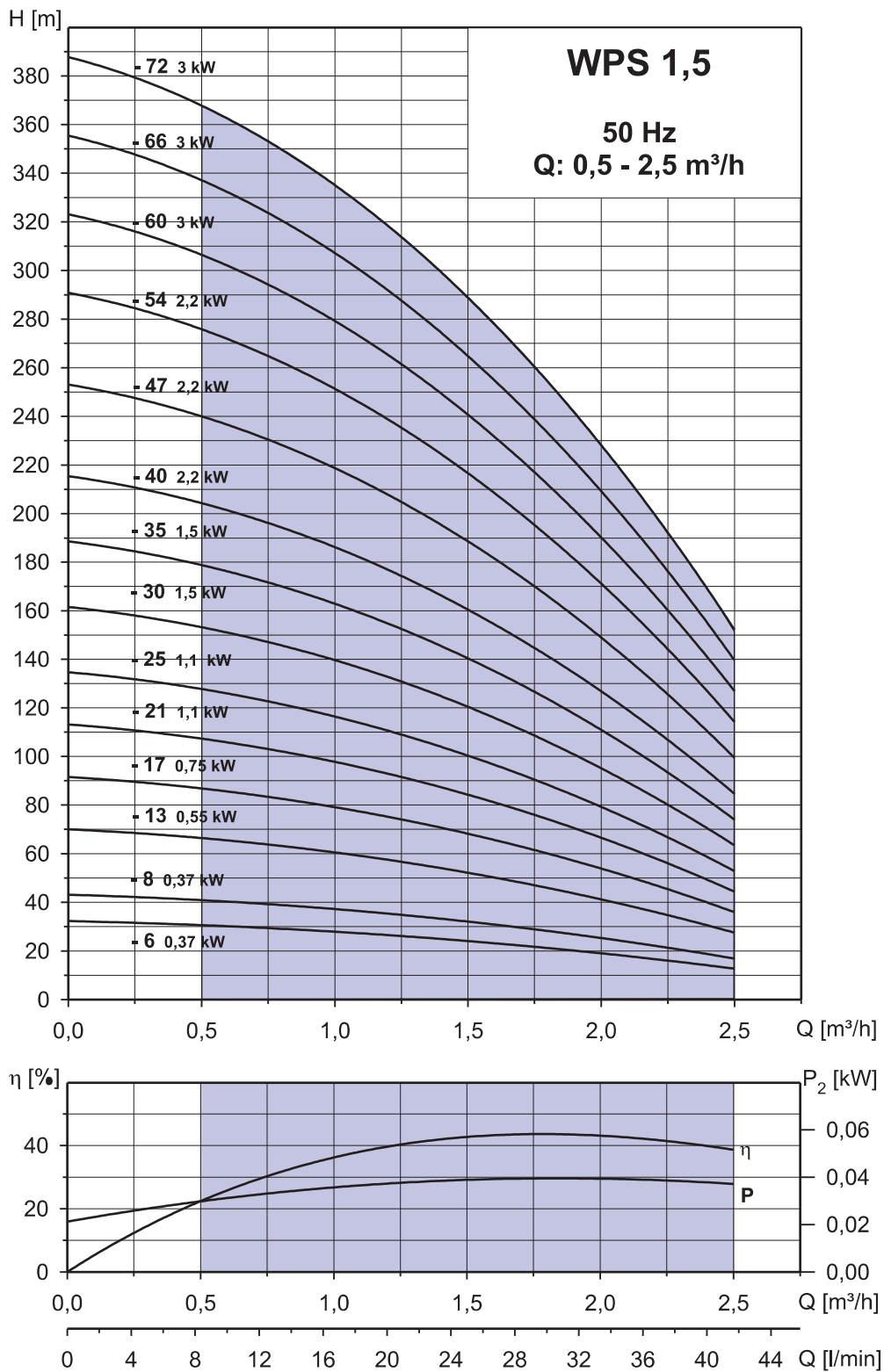



WPS Submersible Pumps Type WPS 1,5

Technical Data

Type	[KW] [HP]		Motor				RPM [min ⁻¹]	Dimensions [mm]				Weight [kg]	
			I _n [A]			A		B		C		Pump- End	Pump + Motor
			1x230 V	3x220 V	3x400 V			1x230 V	3x220 V 3x400 V	1x230 V	3x220 V 3x400 V		
WPS 1,5-6	0,37	0,50	3,20	1,50	0,90	2900	349	242	223	591	572	3,8	11,1
WPS 1,5-8	0,37	0,50	3,60	1,80	1,10	2865	397	242	223	639	620	4,4	11,7
WPS 1,5-13	0,55	0,75	5,70	2,60	1,50	2855	517	271	242	788	759	6,0	14,3
WPS 1,5-17	0,75	1,00	6,90	3,50	2,00	2870	623	299	271	922	894	7,4	17,0
WPS 1,5-21	1,10	1,50	8,00	4,20	2,80	2910	711	327	299	1038	1010	8,7	19,5
WPS 1,5-25	1,10	1,50	8,90	4,70	3,00	2840	807	327	299	1134	1106	10,0	20,8
WPS 1,5-30	1,50	2,00	9,50	5,70	3,30	2900	928	356	327	1284	1255	11,6	23,7
WPS 1,5-35	1,50	2,00	11,10	6,60	3,80	2855	1048	356	327	1404	1375	13,3	25,4
WPS 1,5-40	2,20	3,00	12,10	8,60	5,10	2880	1169	460	356	1629	1525	14,6	28,1
WPS 1,5-47	2,20	3,00	14,50	9,10	5,40	2860	1338	460	356	1798	1694	16,9	29,5
WPS 1,5-54	2,20	3,00	15,90	9,50	5,60	2840	1506	460	356	1966	1862	19,1	32,6
WPS 1,5-60	3,00	4,00	-	11,20	6,80	2880	1651	-	423	-	2074	21,0	37,0
WPS 1,5-66	3,00	4,00	-	11,80	7,20	2865	1796	-	423	-	2219	22,9	38,9
WPS 1,5-72	3,00	4,00	-	12,40	7,50	2850	1941	-	423	-	2364	24,9	40,9

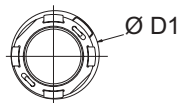
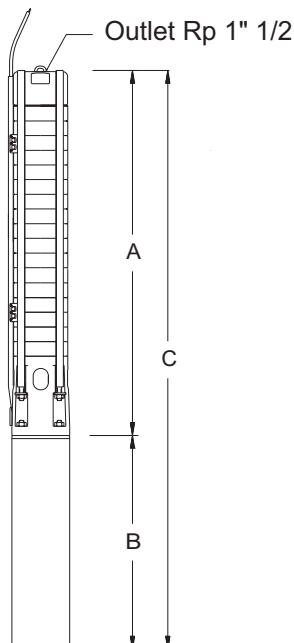

Diameter D1 maximum dimensions: - pump-end: 96,5 mm
- pump with motor: 98,0 mm

Performance curves following ISO 2548 Class C, Annex B

Motor data: Franklin Electric

Coupling to motor in accordance with NEMA standard



WELL PUMPS

**WPS Submersible Pumps
Type WPS 2,5**

Stainless Steel Submersible pumps 4"

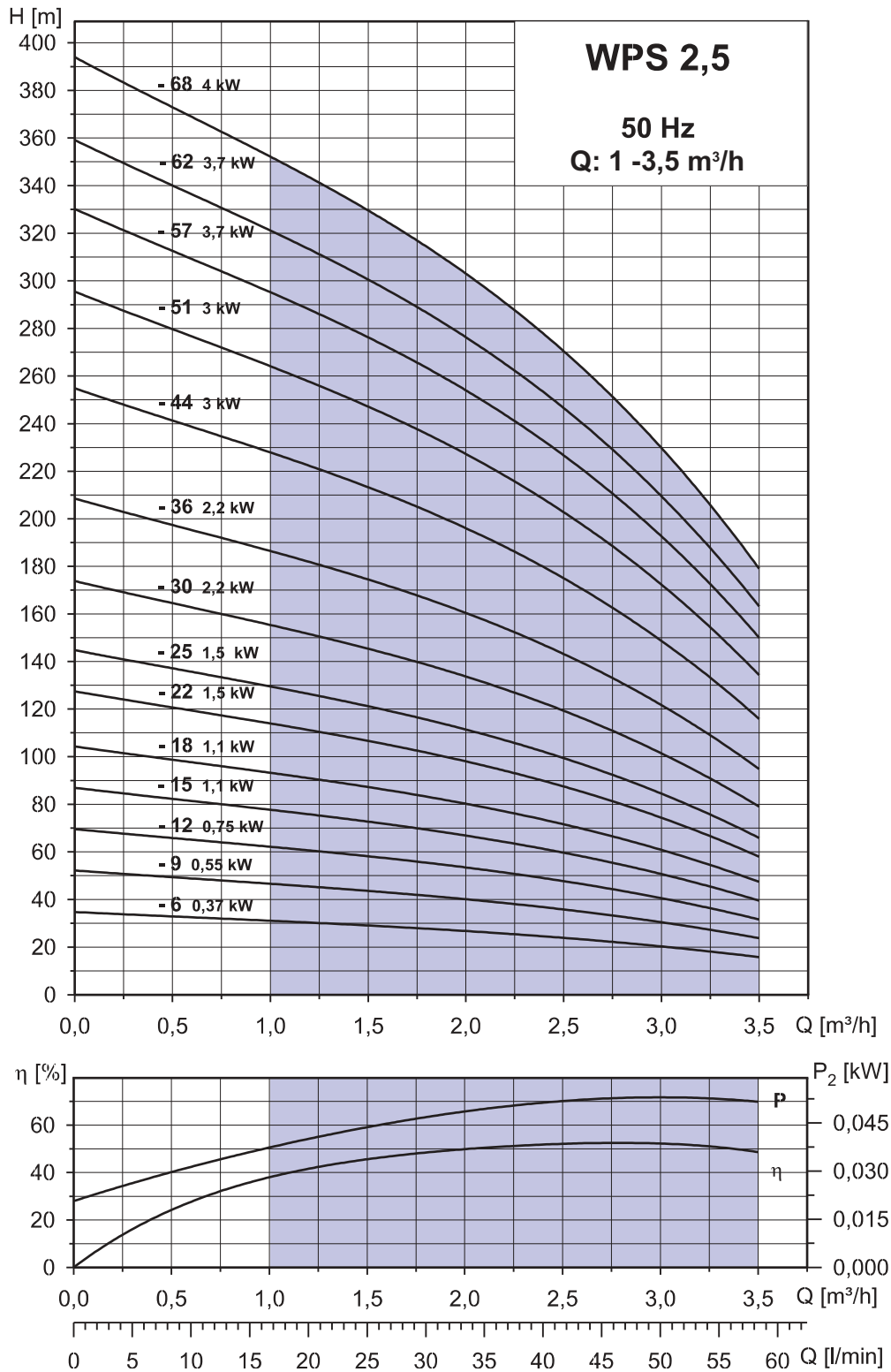



WPS Submersible Pumps Type WPS 2,5

Technical Data

Type	Motor		Motor				RPM [min ⁻¹]	Dimensions [mm]				Weight [kg]	
	[KW]	[HP]	I _n [A]			A		B		C		Pump- End	Pump + Motor
			1x230 V	3x220 V	3x400 V			1x230 V	3x220 V 3x400 V	1x230 V	3x220 V 3x400 V		
WPS 2,5-6	0,37	0,50	3,60	1,50	1,10	2865	349	242	223	591	572	3,8	11,1
WPS 2,5-9	0,55	0,75	5,70	2,60	1,50	2855	421	271	242	692	663	4,8	13,1
WPS 2,5-12	0,75	1,00	6,90	3,50	2,00	2870	493	299	271	792	764	5,8	15,4
WPS 2,5-15	1,10	1,50	8,70	4,50	2,90	2900	566	327	299	883	865	6,3	17,1
WPS 2,5-18	1,10	1,50	8,90	4,70	3,00	2840	638	327	299	965	937	7,7	18,5
WPS 2,5-22	1,50	2,00	9,80	6,30	3,60	2880	734	356	327	1090	1061	9,0	21,1
WPS 2,5-25	1,50	2,00	11,10	6,60	3,80	2855	807	356	327	1163	1134	10,0	22,1
WPS 2,5-30	2,20	3,00	12,50	8,80	5,20	2860	928	460	356	1388	1284	11,6	25,1
WPS 2,5-36	2,20	3,00	15,90	9,50	5,60	2840	1072	460	356	1532	1428	13,7	27,2
WPS 2,5-44	3,00	4,00	-	12,00	7,00	2880	1265	-	423	-	1688	16,3	32,3
WPS 2,5-51	3,00	4,00	-	12,40	7,20	2865	1434	-	423	-	1857	18,7	34,7
WPS 2,5-57	3,70	5,00	-	15,00	8,80	2870	1579	-	545	-	2124	20,6	41,5
WPS 2,5-62	3,70	5,00	-	15,50	9,10	2855	1699	-	545	-	2244	22,3	43,2
WPS 2,5-68	4,00	5,50	-	17,00	10,00	2855	1844	-	583	-	2427	24,2	48,3

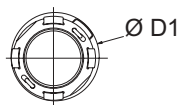
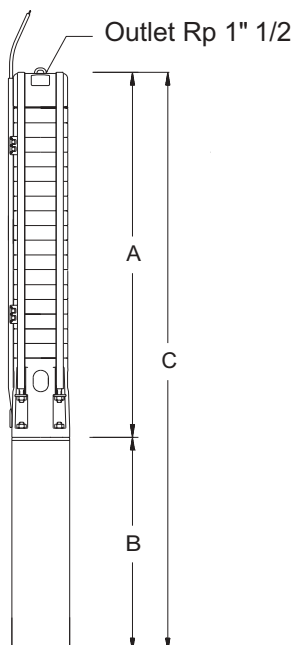

Diameter D1 maximum dimensions: - pump-end: 96,5 mm
- pump with motor: 98,0 mm

Performance curves following ISO 2548 Class C, Annex B

Motor data: Franklin Electric

Coupling to motor in accordance with NEMA standard



WELL PUMPS

**WPS Submersible Pumps
Type WPS 4**

Stainless Steel Submersible pumps 4''

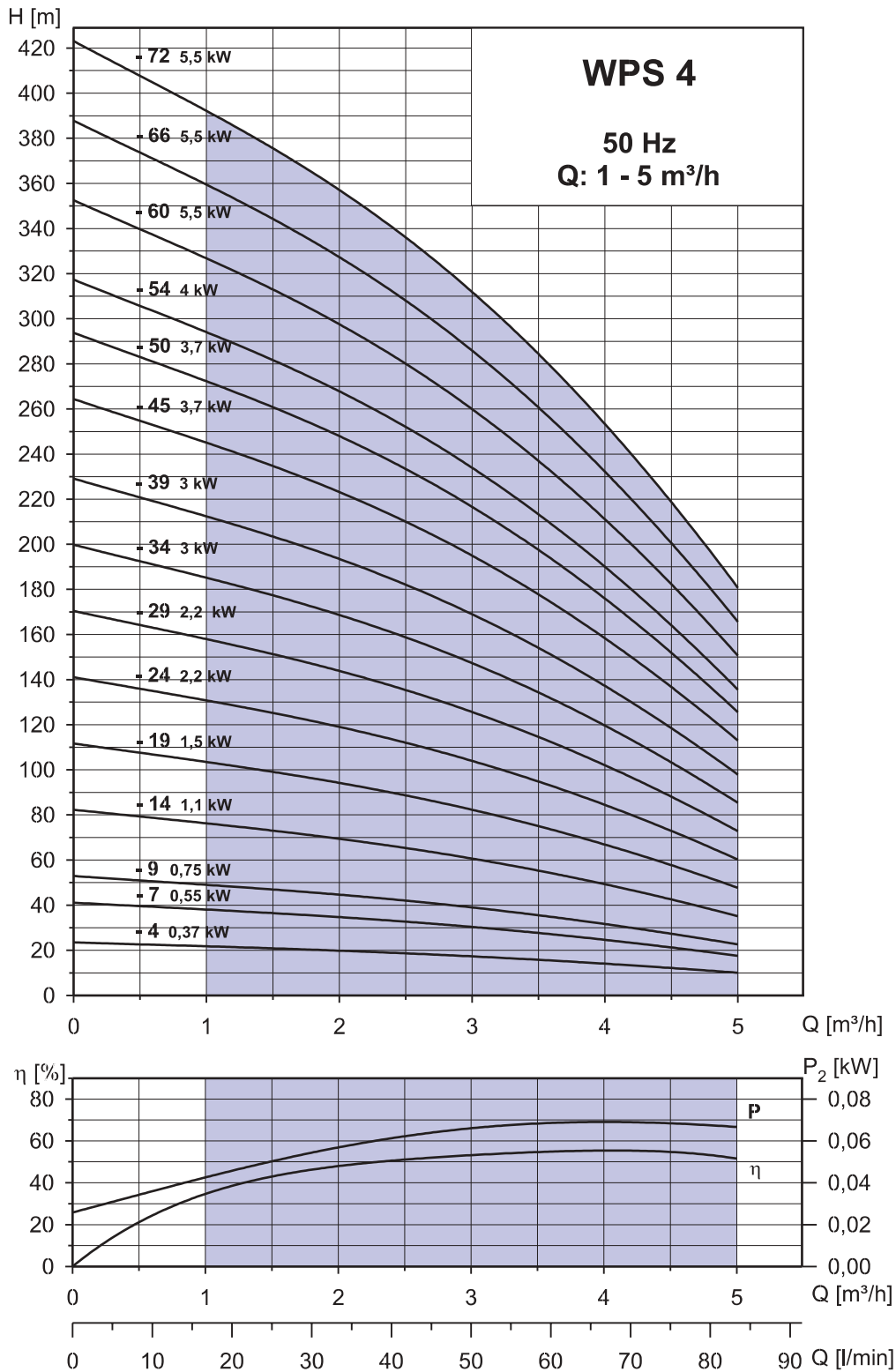



WPS Submersible Pumps Type WPS 4

Technical Data

Type	Motor		Motor				RPM [min ⁻¹]	Dimensions [mm]				Weight [kg]	
	[KW]	[HP]	I _n [A]			A		B		C		Pump- End	Pump + Motor
			1x230 V	3x220 V	3x400 V			1x230 V	3x220 V 3x400 V	1x230 V	3x220 V 3x400 V		
WPS 4-4	0,37	0,50	3,60	1,50	1,10	2865	300	242	223	542	523	3,2	10,5
WPS 4-7	0,55	0,75	5,70	2,60	1,50	2855	373	271	242	644	615	4,2	12,5
WPS 4-9	0,75	1,00	6,90	3,50	2,00	2870	421	299	271	720	692	4,9	14,5
WPS 4-14	1,10	1,50	8,90	4,70	3,00	2840	542	327	299	869	841	6,6	17,4
WPS 4-19	1,50	2,00	11,10	6,60	3,80	2855	662	356	327	1018	989	8,3	20,4
WPS 4-24	2,20	3,00	12,80	9,00	5,30	2860	783	460	356	1243	1139	10,0	23,5
WPS 4-29	2,20	3,00	15,90	9,50	5,60	2840	903	460	356	1363	1259	11,7	25,2
WPS 4-34	3,00	4,00	-	12,10	7,00	2880	1024	-	423	-	1447	13,4	29,4
WPS 4-39	3,00	4,00	-	12,40	7,20	2865	1145	-	423	-	1568	15,1	31,1
WPS 4-45	3,70	5,00	-	15,10	8,80	2860	1289	-	545	-	1834	17,1	38,0
WPS 4-50	3,70	5,00	-	15,50	9,10	2855	1410	-	545	-	1955	18,8	39,7
WPS 4-54	4,00	5,50	-	17,00	10,00	2855	1506	-	583	-	2089	20,2	44,3
WPS 4-60	5,50	7,50	-	20,80	11,50	2880	1651	-	698	-	2349	22,2	51,6
WPS 4-66	5,50	7,50	-	22,00	12,50	2865	1796	-	698	-	2494	24,3	53,7
WPS 4-72	5,50	7,50	-	22,80	13,20	2850	1941	-	698	-	2639	26,3	55,7

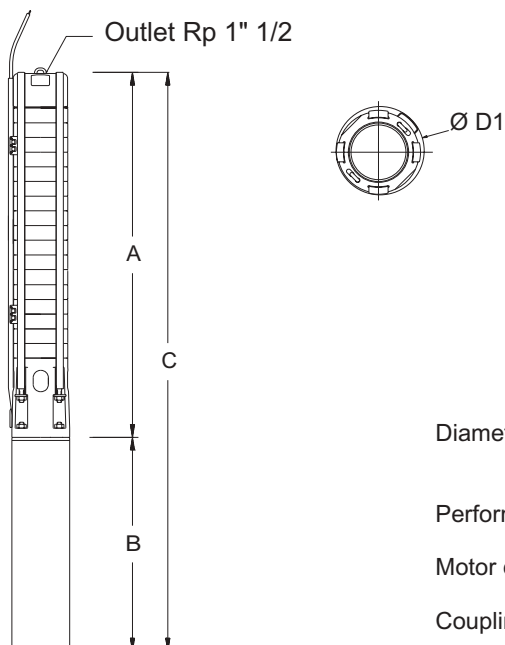

Diameter D1 maximum dimensions: - pump-end: 96,5 mm
- pump with motor: 98,0 mm

Performance curves following ISO 2548 Class C, Annex B

Motor data: Franklin Electric

Coupling to motor in accordance with NEMA standard



WELL PUMPS

**WPS Submersible Pumps
Type WPS 7**

Stainless Steel Submersible pumps 4"

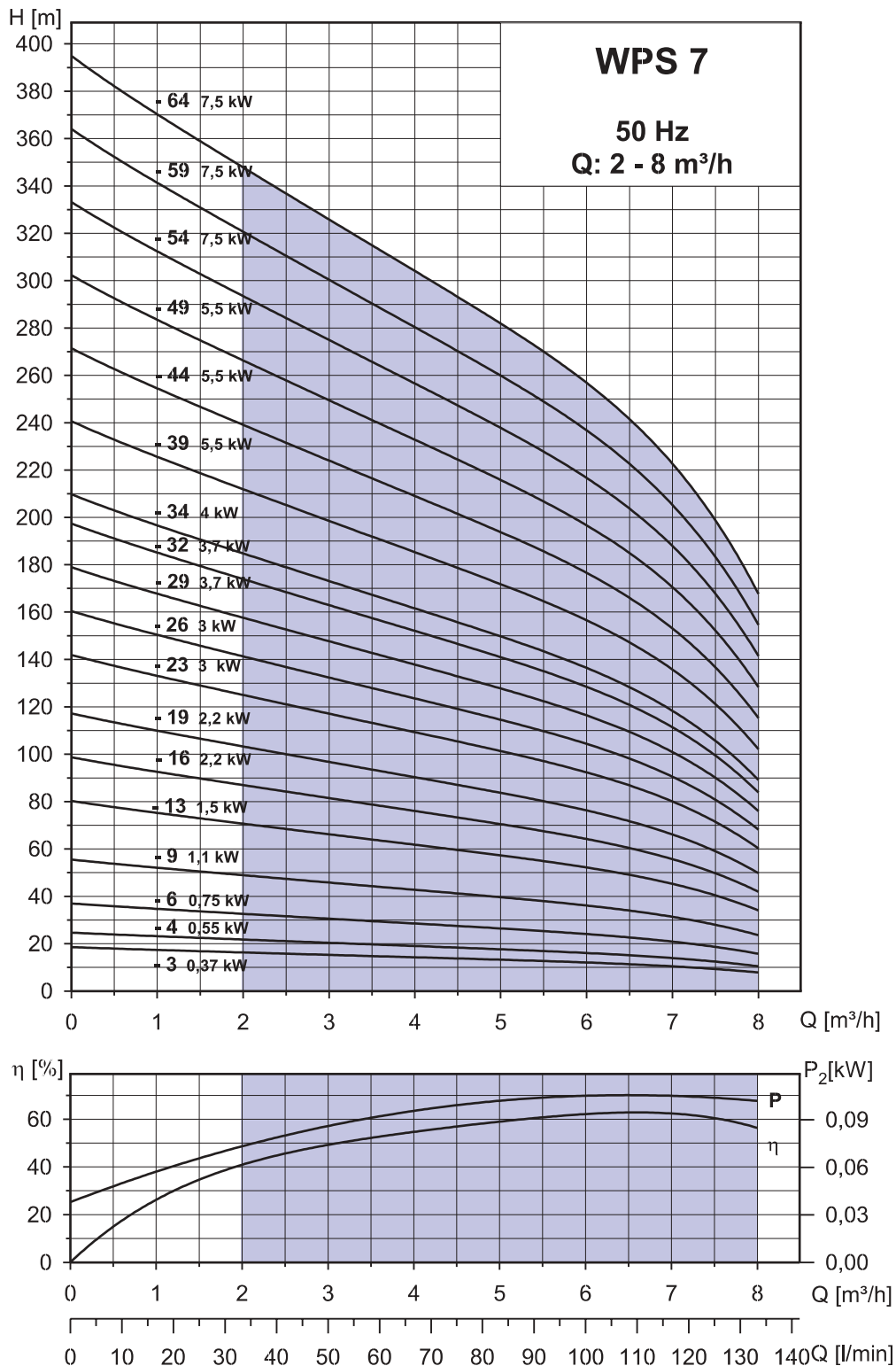



WPS Submersible Pumps Type WPS 7

Technical Data

Type	[KW] [HP]		Motor				RPM [min ⁻¹]	Dimensions [mm]				Weight [kg]	
			I _n [A]			A		B		C		Pump- End	Pump + Motor
			1x230 V	3x220 V	3x400 V			1x230 V	3x220 V 3x400 V	1x230 V	3x220 V 3x400 V		
WPS 7-3	0,37	0,50	3,60	1,50	1,10	2865	276	242	223	519	500	2,9	10,2
WPS 7-4	0,55	0,75	5,70	2,60	1,50	2855	300	271	242	571	542	3,2	11,5
WPS 7-6	0,75	1,00	6,90	3,50	2,00	2870	349	299	271	648	620	3,9	13,5
WPS 7-9	1,10	1,50	8,90	4,70	3,00	2840	421	327	299	748	720	5,0	15,8
WPS 7-13	1,50	2,00	11,10	6,60	3,80	2855	517	356	327	873	844	6,4	18,5
WPS 7-16	2,20	3,00	12,80	8,90	5,20	2870	590	460	356	1050	946	7,5	21,0
WPS 7-19	2,20	3,00	15,90	9,50	5,60	2840	662	460	356	1122	1118	8,5	22,0
WPS 7-23	3,00	4,00	-	11,60	6,60	2880	759	-	423	-	1182	9,9	25,9
WPS 7-26	3,00	4,00	-	12,40	7,20	2865	831	-	423	-	1254	11,0	27,0
WPS 7-29	3,70	5,00	-	14,60	8,30	2870	903	-	545	-	1448	12,1	33,0
WPS 7-32	3,70	5,00	-	15,50	9,10	2855	976	-	545	-	1521	13,1	34,0
WPS 7-34	4,00	5,50	-	17,00	10,00	2855	1024	-	583	-	1607	13,8	37,9
WPS 7-39	5,50	7,50	-	20,70	11,50	2890	1145	-	698	-	1843	15,6	45,0
WPS 7-44	5,50	7,50	-	21,90	12,50	2865	1266	-	698	-	1964	17,4	46,8
WPS 7-49	5,50	7,50	-	22,80	13,20	2850	1386	-	698	-	2084	19,2	48,6
WPS 7-54	7,50	10,00	-	-	17,50	2865	1506	-	774	-	2280	20,9	53,9
WPS 7-59	7,50	10,00	-	-	18,30	2855	1628	-	774	-	2402	22,7	55,7
WPS 7-64	7,50	10,00	-	-	19,10	2840	1748	-	774	-	2522	24,5	59,5

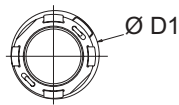
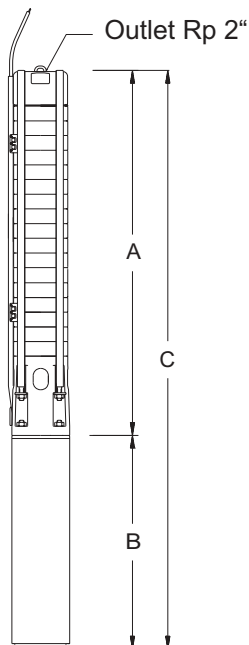

Diameter D1 maximum dimensions: - pump-end: 96,5 mm
- pump with motor: 98,0 mm

Performance curves following ISO 2548 Class C, Annex B

Motor data: Franklin Electric

Coupling to motor in accordance with NEMA standard



WELL PUMPS

**WPS Submersible Pumps
Type WPS 12**

Stainless Steel Submersible pumps 4"

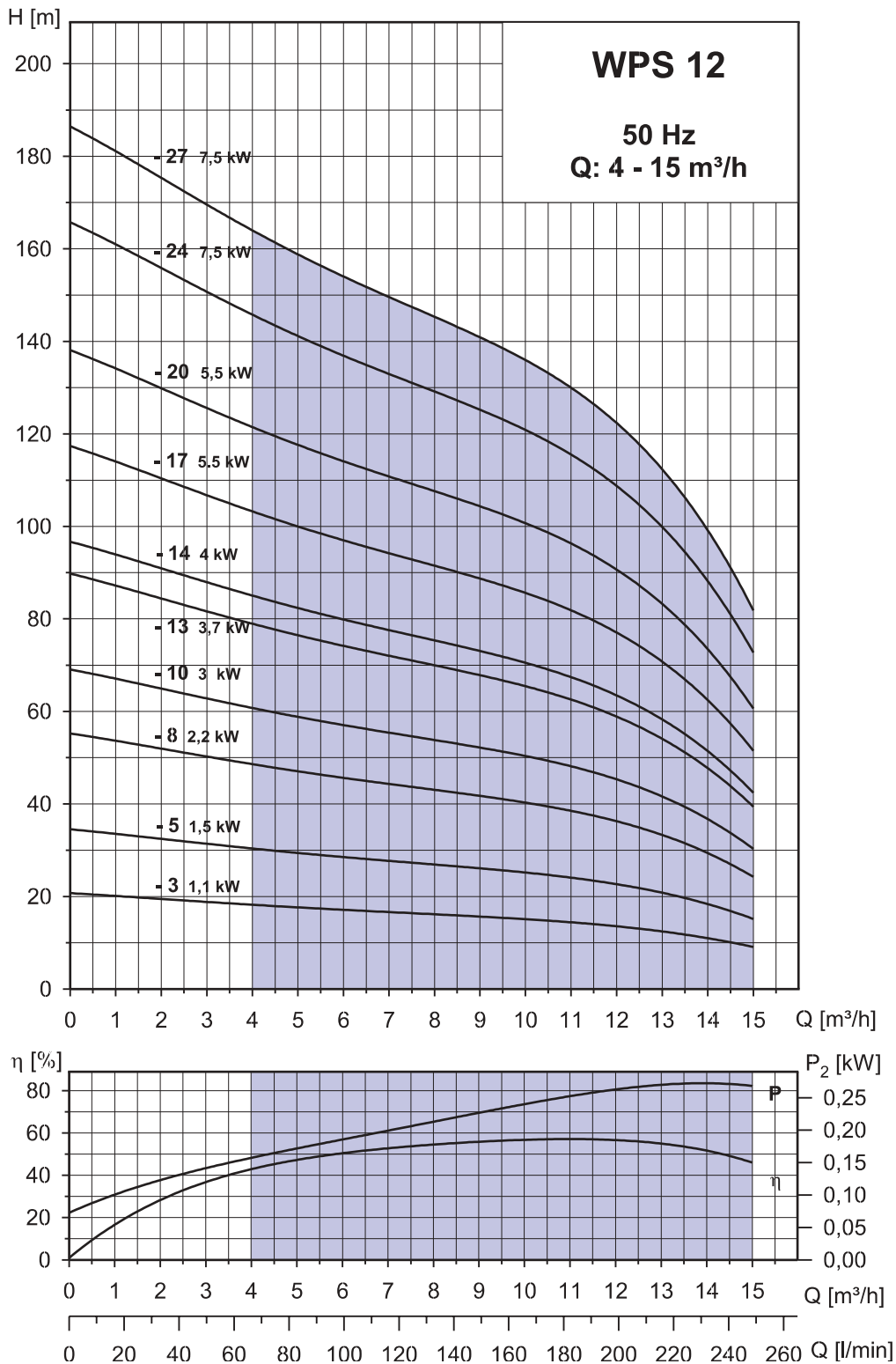



WELL PUMPS

WPS Submersible Pumps Type WPS 12

Technical Data

Type	Motor		Motor				RPM [min ⁻¹]	Dimensions [mm]				Weight [kg]	
	[KW]	[HP]	I _n [A]			A		B		C		Pump- End	Pump + Motor
			1x230 V	3x220 V	3x400 V			1x230 V	3x220 V 3x400 V	1x230 V	3x220 V 3x400 V		
WPS 12-3	1,10	1,50	8,90	4,70	3,00	2840	327	327	299	654	626	3,1	13,9
WPS 12-5	1,50	2,00	11,10	6,60	3,80	2855	405	356	327	761	732	3,9	16,0
WPS 12-8	2,20	3,00	15,90	9,50	5,60	2840	522	460	356	982	878	5,2	18,7
WPS 12-10	3,00	4,00	-	12,40	7,20	2565	600	-	423	-	1023	6,1	22,1
WPS 12-13	3,70	5,00	-	15,50	9,10	2855	717	-	545	-	1265	7,4	28,4
WPS 12-14	4,00	5,50	-	17,00	10,00	2855	756	-	583	-	1339	7,8	29,6
WPS 12-17	5,50	7,50	-	21,90	12,50	2865	873	-	698	-	1571	9,1	36,4
WPS 12-20	5,50	7,50	-	22,80	13,20	2850	990	-	698	-	1688	10,4	37,7
WPS 12-24	7,50	10,00	-	-	18,30	2855	1146	-	774	-	1920	12,1	44,1
WPS 12-27	7,50	10,00	-	-	19,10	2840	1263	-	774	-	2037	13,4	45,4

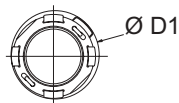
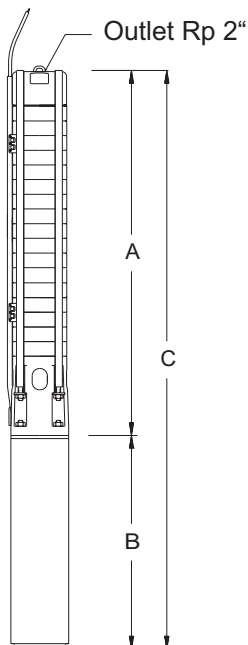

Diameter D1 maximum dimensions: - pump-end: 96,5 mm
- pump with motor: 98,0 mm

Performance curves following ISO 2548 Class C, Annex B

Motor data: Franklin Electric

Coupling to motor in accordance with NEMA standard

Pump Section and list of main components

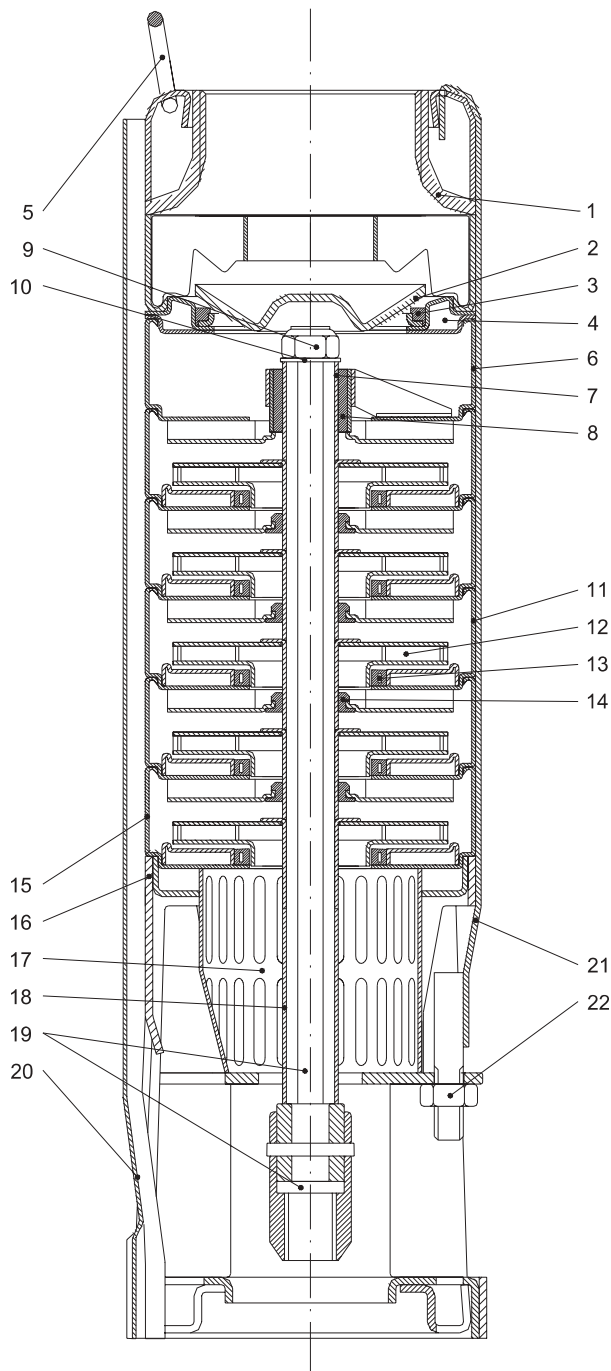

Radial Flow Pump Pompe Radiale

WPS 1,5
WPS 2,5
WPS 4
WPS 7

Item	Description	Material
1	Discharge chamber	AISI 304
2	Valve cone	AISI 304
3	Valve seat	NBR + AISI 316
4	Retainer for valve seat	AISI 304
5	Hook	AISI 304
6	Top diffusor	AISI 304
7	Spacer	AISI 304
8	Top bearing	NBR + AISI 316
9	Nut M8	AISI 304
10	Washer	AISI 304
11	Diffusor	AISI 304

Item	Description	Material
12	Impeller	AISI 304
13	Neck ring	NBR + AISI 316
14	Intermediate bearing	NBR
15	Bottom diffusor	AISI 304
16	Suction interconnector	AISI 304
17	Strainer	AISI 304
18	Spacer	AISI 304
19	Shaft with NEMA coupling	AISI 304
20	Cable guard	AISI 304
21	Strap	AISI 304
22	Nut M8	AISI 304

Section de pompe et liste des composants

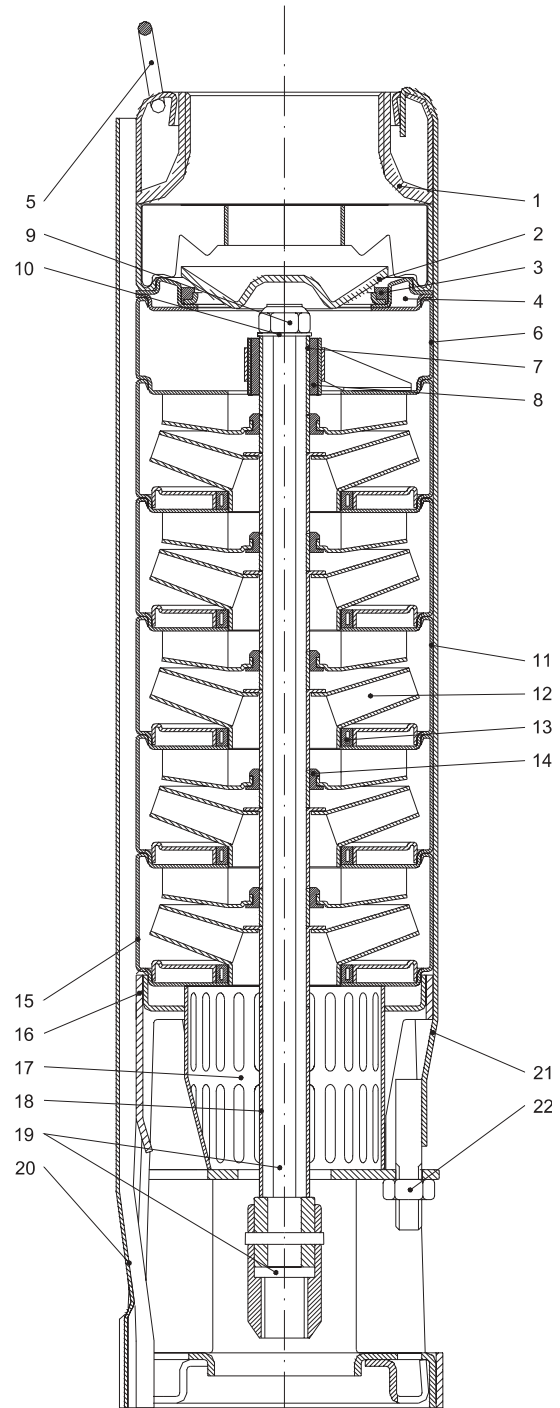

Mixed Flow Pump Pompe Semi Axiale

WPS 12

Pos	Description	Matériel
1	Tête de pompe	AISI 304
2	Clapet anti-retour	AISI 304
3	Siège clapet	NBR + AISI 316
4	Support clapet	AISI 304
5	Crochet	AISI 304
6	Chambre supérieure	AISI 304
7	Bague du haut	AISI 304
8	Palier "Top bearing"	NBR + AISI 316
9	Ecrou M8	AISI 304
10	Rondelle	AISI 304
11	Diffuseur	AISI 304

Pos	Description	Matériel
12	Roue	AISI 304
13	Joint "Neck Ring"	NBR + AISI 316
14	Palier intermédiaire	NBR
15	Diffuseur de bas	AISI 304
16	Pied	AISI 304
17	Crépine	AISI 304
18	Bague de hauteur	AISI 304
19	Axe accouplement NEMA	AISI 304
20	Protège cable	AISI 304
21	Tirant	AISI 304
22	Ecrous M8	AISI 304